

**INTRODUCTION**

The S5G9801X01 and S5G9803X01 are CMOS integrated circuits for the infrared ray remote receiver, used with the S5G9802, which can be applied to TV, VCR, VDP, CDP and AV controller. The S5G9801X01 is a 16-DIP type and is able to control 10 functions. The S5G9803X01 is a 24-DIP type and is able to control 18 functions.

**FEATURES**

- Output for continuous pulse, toggle pulse and single pulse are provided (Toggle pulse is available only for S5G9803X01)
- A single terminal type oscillator by means of RC is provided
- Containing custom code detection circuit for code check with the transmitter (To prevent interferences with other models)
- Able to output in parallel method multiple keying signals sent from transmitter.

The S5G9801X01 can output up to 5 functions, and the S5G9803X01 can output up to 6 functions in parallel method.

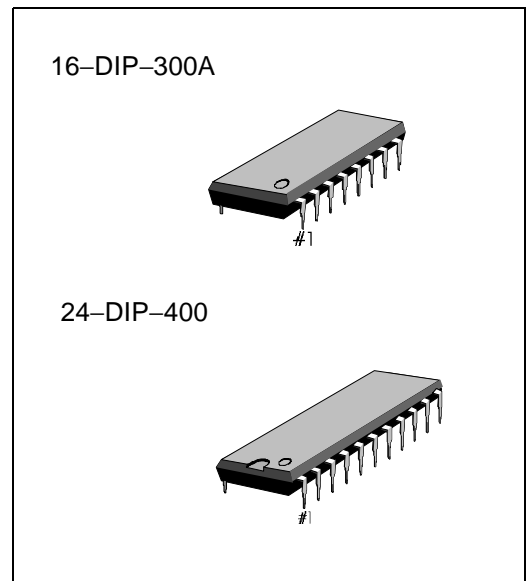

**ORDERING INFORMATION**

Device	Package	Operating Temperature
S5G9801X01-D0B0	16-DIP-300A	- 20°C - +75°C
S5G9803X01-D0B0	24-DIP-400	

**BLOCK DIAGRAM**

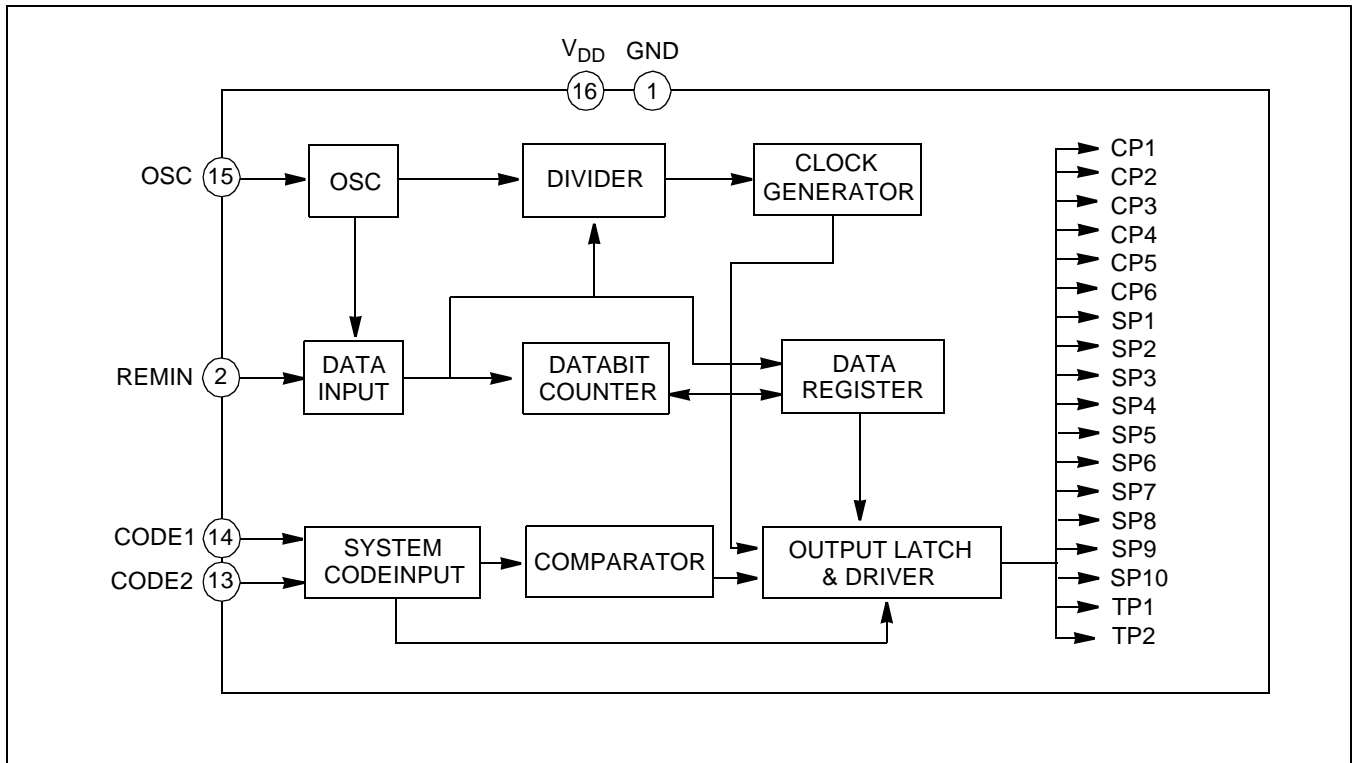

Figure 1.

PIN CONFIGURATION

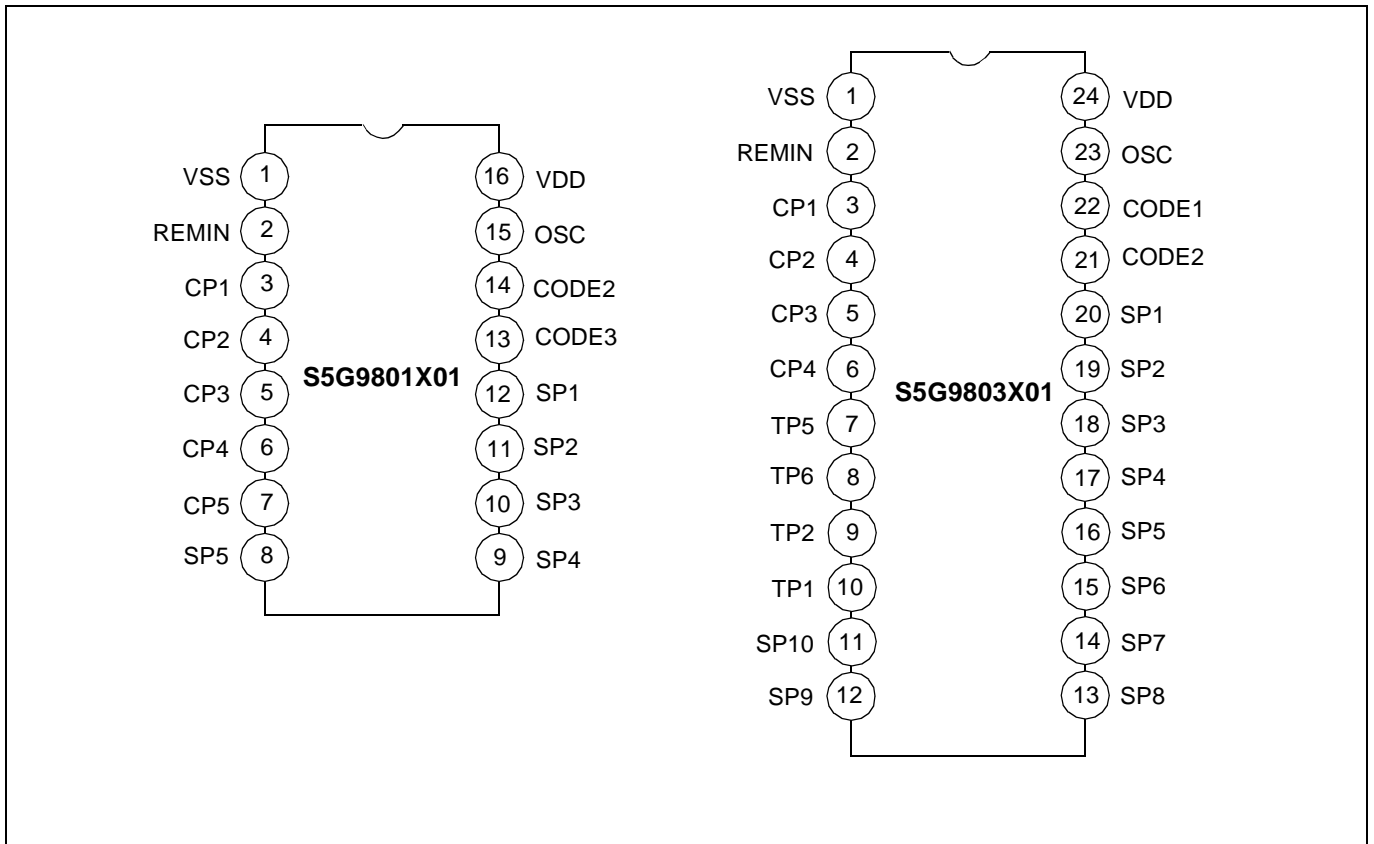

Figure 2.

## PIN DESCRIPTION

Pin No		Symbol	Input Output	Description
S5G9801	S5G9803			
1	1	GND	Ground	–
2	2	REMIN	Receiving Signal Input	Instruction signal input with the carrier signal eliminated.
3 – 7	–	CP1 – SP5	Continuous Signal output	As long as receiving is input, this output is held at “H” level. After releasing a key, output is held at “H” level for about 160 msec.
–	3 – 8	CP1 – CP6		
–	9 – 10	TP1, TP2	Toggle Signal Output	When receiving signal is input, output is toggled.
8 ~ 12	–	SP1 – SP5	Single Signal Output	When receiving signal is input, output is held at “H” level only for about 107 msec.
–	11 – 20	SP1 – SP10		
13, 14	21, 22	CODE	Code Input	A code set at this terminal is compared with trans- mitter code and if they agree with each other, input is accepted (built-in pull-up resistor).
15	33	OSC	Timing Oscillation	A capacitor and a resistor are connected in parallel method between this terminal and VSS.
16	24	VDD	Power Supply	–

## ABSOLUTE MAXIMUM RATINGS (TA = 25°C)

Characteristic	Symbol	Value	Unit
Supply Voltage	V <sub>DD</sub>	0 – 6	V
Input/Output Voltage	V <sub>IN</sub> V <sub>OUT</sub>	V <sub>SS</sub> – 0.3 – V <sub>DD</sub> + 0.3	V
Power Dissipation	P <sub>D</sub>	200	mW
Operating Temperature	T <sub>OPR</sub>	–20 – 75	°C
Storage Temperature	T <sub>STG</sub>	–55 – 125	°C

**ELECTRICAL CHARACTERISTICS**

(Ta = 25 °C, V<sub>DD</sub> = 5 V, unless otherwise specified)

Characteristic		Symbol	Test Conditions	Min.	Typ.	Max.	Unit
Operating Voltage		V <sub>DD</sub>	Ta = -25°C ~ 75°C	4.5	-	5.5	V
Operating Current		I <sub>DD</sub>	Output Without Load	-	-	1.0	mA
Frequency Deviation		f <sub>OSC</sub>	Ta = -25°C ~ 75°C V <sub>DD</sub> = 4.5V ~ 5.5V	27	38	57	kHz
Frequency Stability		ΔV <sub>FOXC</sub>	Ta = -25°C V <sub>DD</sub> = 4.5V ~ 5.5V	-5	-	5	%
		ΔT <sub>FOSC</sub>	Ta = -30°C ~ 75°C	-5	-	5	%
Output Current	“H” Level	I <sub>OH</sub>	All Output, V <sub>OH</sub> = 4V	-	-2.0	-1.0	mA
	“L” Level	I <sub>OL</sub>	All Output, V <sub>OL</sub> = 1V	1.0	2.5	-	mA
Input Current	“H” Level	I <sub>IH</sub>	Code Terminal, V <sub>IH</sub> = 5.0V	-1.0	-	1.0	uA
Pull-up Resistor		R <sub>UP</sub>	REMAIN Terminal	10	20	40	kΩ
Input Circuit Threshold Voltage		V <sub>IH</sub>	REMAIN Terminal	3.5	-	-	V
		V <sub>IL</sub>	REMAIN Terminal	-	-	1.5	V
Hysteresis Width		V <sub>H2S</sub>	-	-	1.0	-	V
Standard osc Frequency		S <sub>FOSC</sub>	-	-	38	-	kHz

## OPERATING PRINCIPLES

### 1. POR (Power On Reset) CIRCUIT

To initialize the internal state at time of power ON, it is necessary to perform the initialization. The initialization is carried out when a capacitor is connected to the code bit terminal.

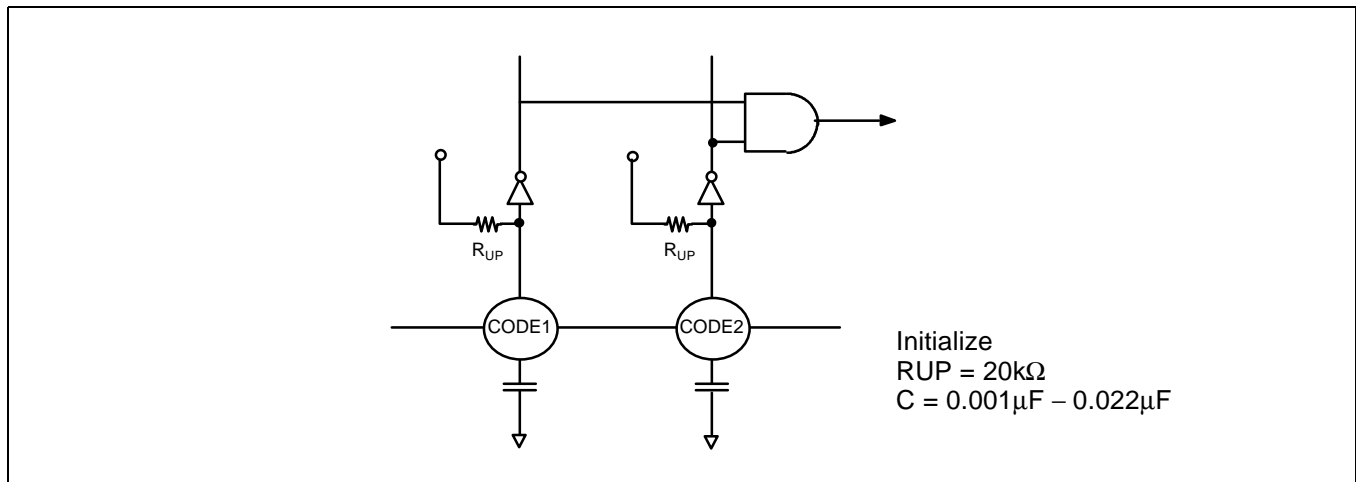

Figure 3.

In the case of S5G9803, connect a capacitor to CODE2 and CODE3.

### 2. OSCILLATION CIRCUIT

The RC oscillation circuit is normally operated at 38kHz oscillation frequency. (The RC is connected between OSC terminal and VSS.)

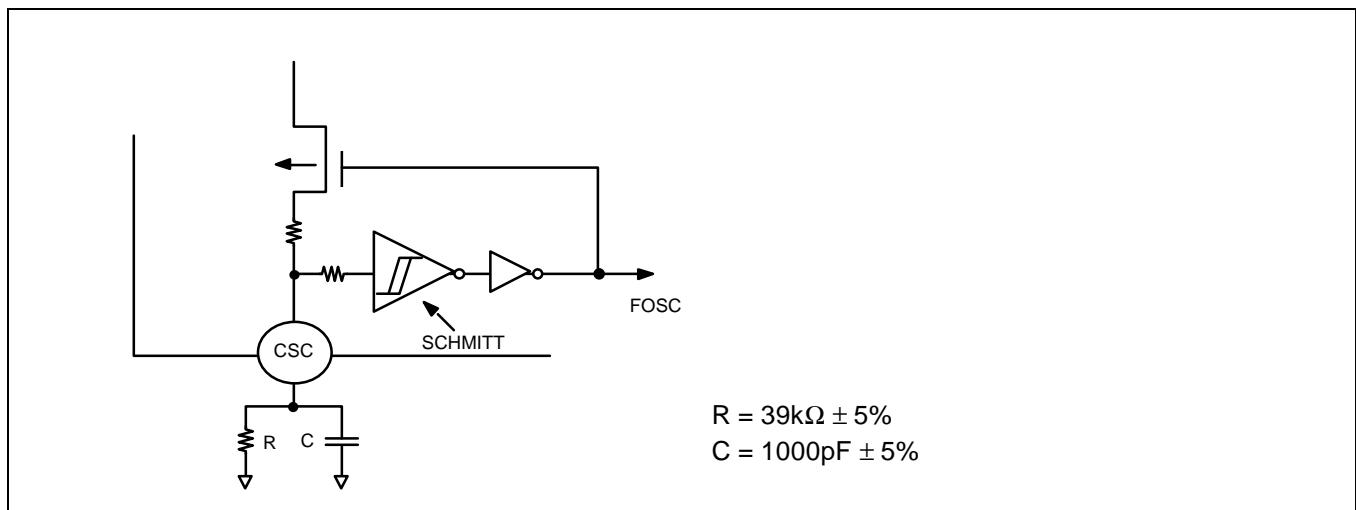

Figure 4.

Oscillation frequency is about  $38kHz \pm 5kHz$  at  $R = 38k\Omega$  and  $C = 1000pF$ .

**3. RECEIVING SIGNAL INPUT CIRCUIT**

Signal received by the light receiving element is sent through the Pre-Amp to the detector, when a 38 kHz carrier wave is eliminated and the signal enters a REMIN PIN of the receiving signal input circuit. The receiving signal input circuit (REMIN) has a built-in Schmitt trigger for shaping receiving signal waveforms to eliminate rounding.

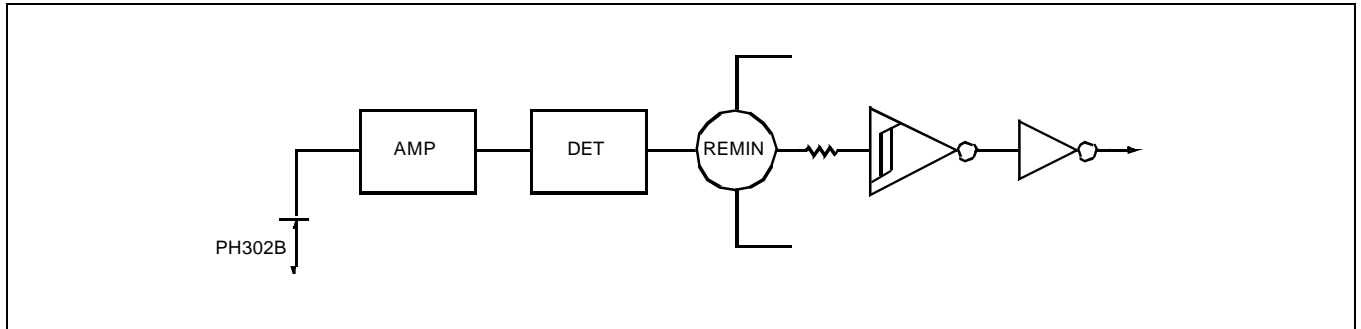

Figure 5.

**4. RECEIVING SIGNAL CHECK**

The receiving signal check is to check the 2-cycle transmitting signal sent from the transmitter to check whether it is a normal signal or not.

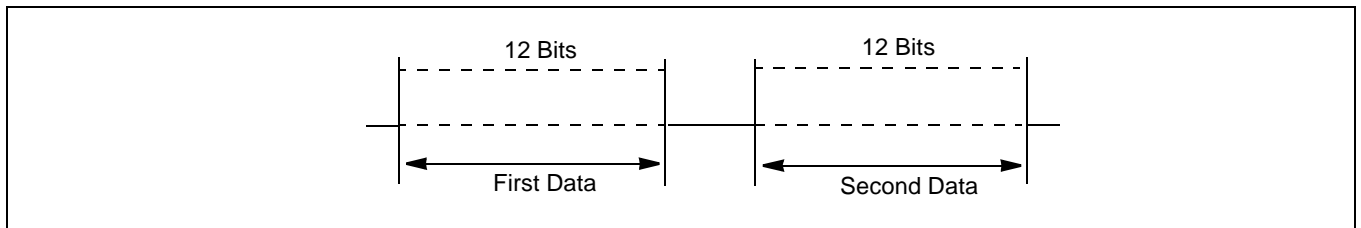

Figure 6.

The first data is stored in the 12-bit data register. Then, when the second data is entered, the previous data is pushed out from the data register one by one. The pushed out data and incoming data are checked to see if they are same. If any errors are caused during the 12-bit receiving data check, the system is reset at that time. And when all receiving data are same, output is raised from L level to H level.

The status of receiving data, register clock and check pulse are shown below. Register clock is provided in the data center by taking frequency margins of the transmitter and the receiver into consideration.

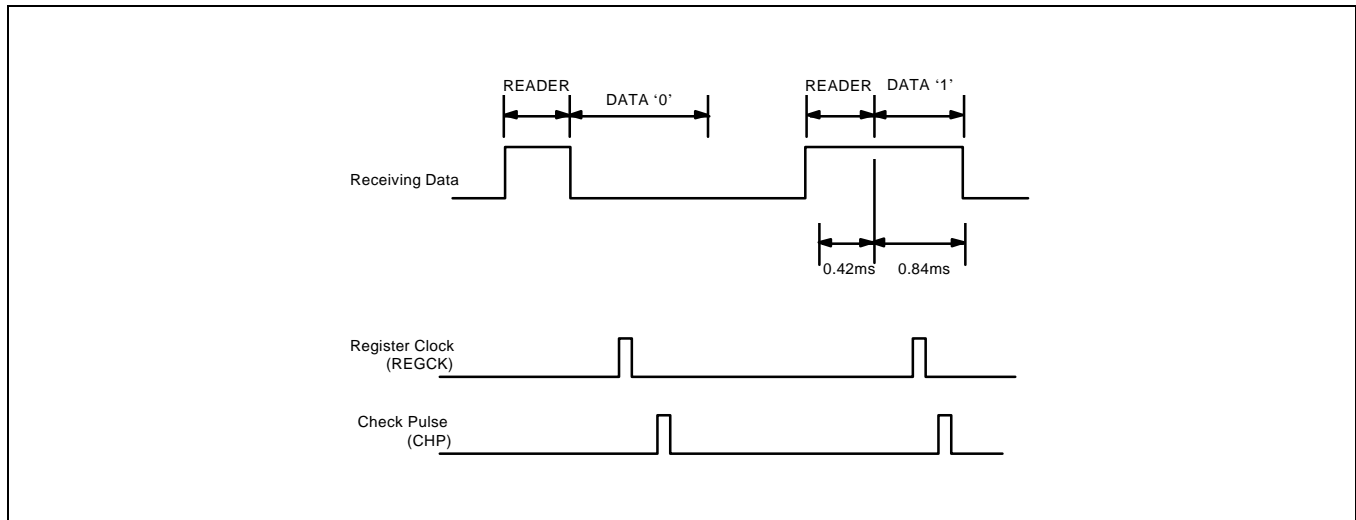

Figure 7.

## 5. CODE BIT COMPARISON

In order to prevent interference with other machines and apparatuses, C1, C2 and C3 code bits are provided for checking whether or not the transmitter codes agree to the receiver codes.

Only when both codes agree, the internal latch pulse is generated to latch receiving data, and output is raised from "L" level to "H" level.

If both codes do not agree, latch pulse is not generated and output remains at "L" level.

Code bits used differ depending on receiver as shown below:

CODE BIT	
C1	C2
C3	C2
0	1
1	0
1	1

S5G9801X01C2, ..... C3 is used.

S5G9803X01C1, ..... C2 is used.

\* CODE BIT "0", "0" cannot be used.



**6. EXPLANATION OF OUTPUT PULSE SP, CP, TP**

1) SP1 – SP10 (Single Pulse)

When a single key is depressed, after checking the 12-bit receiving data, if the data agree, a single pulse is output. The output is raised from “L” level to “H” level and returned again to “L” level after about 107 msec.

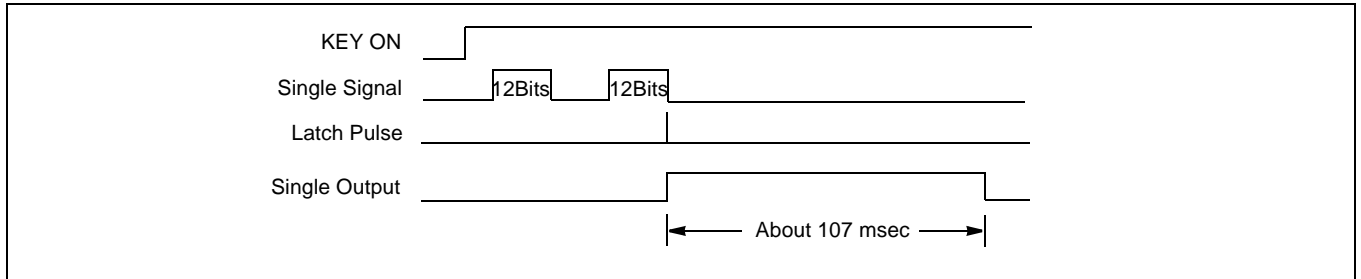

**Figure 8.**

2) CP1 – CP6 (Continuous Pulse)

Continuous pulse is output by the first latch pulse after key ON. Output is kept at “H” level as a long as a continuous signal is input.

When the key is released and continuous signal is stopped about 160 msec later, output is reversed to “L” level by the last latch pulse.

Further, CP1 – CP6 are able to output simultaneously in parallel method, maximum sextet outputs at “H” level by continuous signals sent from the transmitter.

These outputs are optimum as outputs of REC-PLAY, REC-PAUSE and CUE/REVIEW of a tape deck.

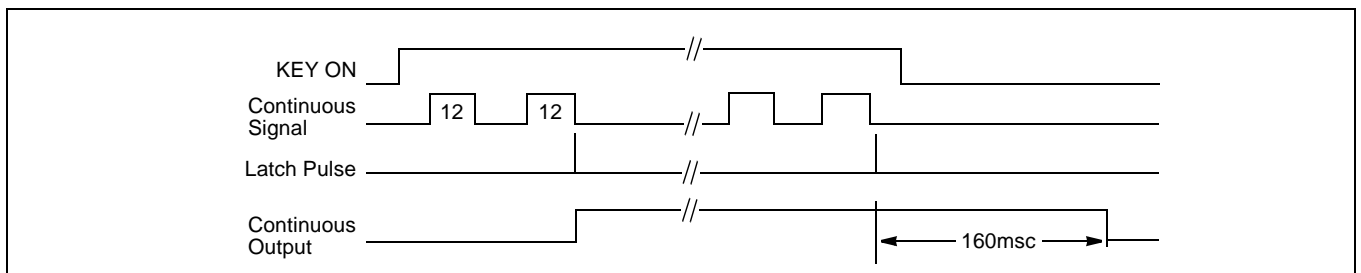
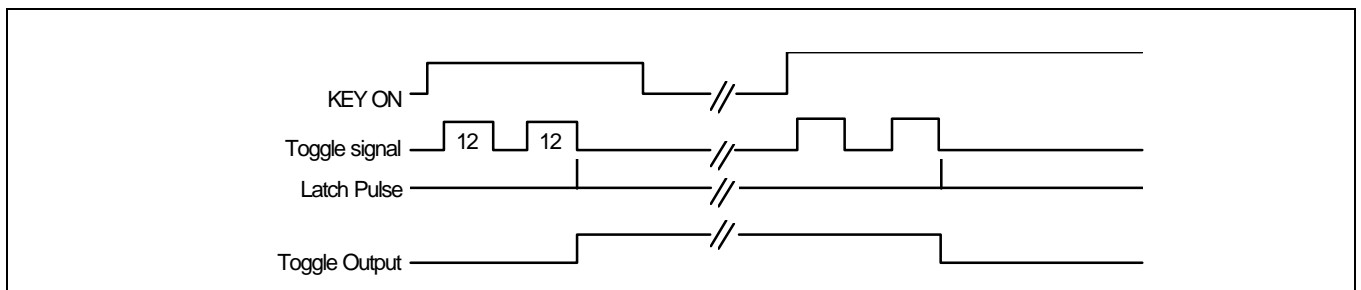

**Figure 9.**

3) TP1, TP2 (Toggle Pulse)

When toggle signal is received, toggle pulse output is reversed.

This toggle pulse is used for power ON, OFF, MUTE, etc.



**Figure 10.**

## 7. CODE TABLE

C1 – C3 code bits are available in addition to the data bits shown below for optional code selection. S5G9803X01 is able to use all keys, but S5G9801X01 can use KEY1 – 5 and KEY 7 – A only for 10 commands.

Key No.	Data Bit										Key No.	Data Bit									
	CT	S1	S2	D1	D2	D3	D4	D5	D6			CT	S1	S2	D1	D2	D3	D4	D5	D6	
1	1	0	0	1	0	0	0	0	0	CONT, CP1	10	0	1	0	0	0	0	1	0	0	SING, SP4
2	1	0	0	0	1	0	0	0	0	CONT, CP2	A	0	1	0	0	0	0	0	1	0	SING, SP5
3	1	0	0	0	0	1	0	0	0	CONT, CP3	B	0	1	0	0	0	0	0	0	1	SING, SP6
4	1	0	0	0	0	0	1	0	0	CONT, CP4	C	0	0	1	1	0	0	0	0	0	SING, SP7
5	1	0	0	0	0	0	0	1	0	CONT, CP5	D	0	0	1	0	1	0	0	0	0	SING, SP8
6	1	0	0	0	0	0	0	0	1	CONT, CP6	E	0	0	1	0	0	1	0	0	0	SING, SP9
7	0	1	0	1	0	0	0	0	0	SING, SP1	F	0	0	1	0	0	0	1	0	0	SING, SP10
8	0	1	0	0	1	0	0	0	0	SING, SP2	G	0	0	1	0	0	0	0	1	0	TOGG, TP1
9	0	1	0	0	0	1	0	0	0	SING, SP3	H	0	0	1	0	0	0	0	0	1	TOGG, TP2

CONT : Continuous, SING : Single, TOGG : Toggle

**NOTE:** S5G9802X01 has 18 function keys, and total 75 commands can be transmitted: 63 commands by the continuous keys of multiple keying is possible and 12 commands by the single-shot keys.

EXAMPLE OF APPLICATION CIRCUIT

1. COMBINATION OF S5G9802X01/S5G9801X01 CODE BITS

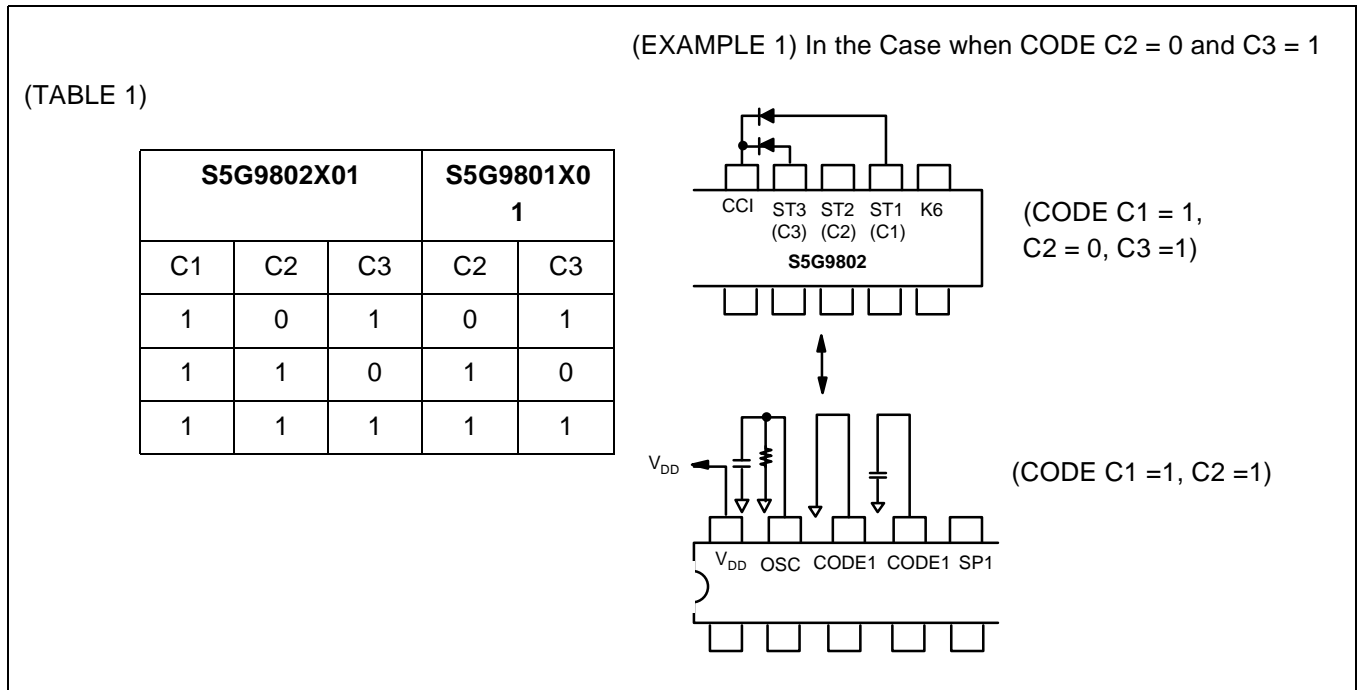

Figure 11.

The combination of code bits of S5G9802X01 and S5G9801X01 is shown in Table 1.

To make the code bit to 1 on S5G9802X01, connect diodes to the CCI terminal from ST1 – ST3 terminals. To set Code Bit at 0, open the circuit.

S5G9801X01 has CODE2 and CODE3 code terminals. Code bit of C1 has been pulled up in IC and C1 is always kept at 1 status.

Therefore, on transmitter S5G9802X01, it is necessary to keep C1 code bit at 1.

2. COMBINATION OF S5G9802/S5G9803 CODE BITS

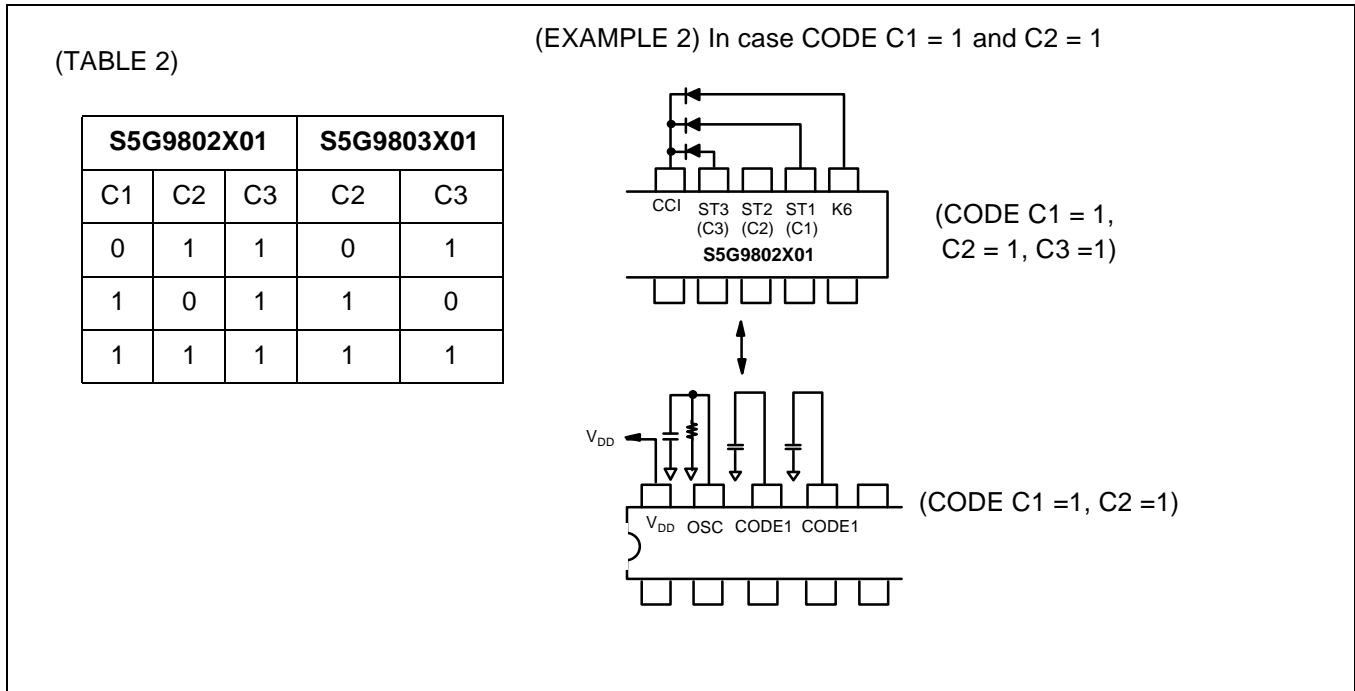

Figure 12.

The combination of code bits of S5G9802X01 and S5G9803X01 is shown in Table 2. S5G9803X01 has CODE1 and CODE2 code terminals. Code bit of C3 has been pulled up in IC and C3 is always kept at 1 status.

Therefore, on transmitter S5G9802X01 it is necessary to keep code bit C3 at 1. To keep code bit C3 at 1, connect a diode to the Cci terminal from ST3 terminal.

3. If input voltage above VDD +0.3 V may be applied to the REMIN Input Terminal (2 PIN), connect about ten resistors in series to the REMIN Input Terminal. (This is to prevent latch-up).

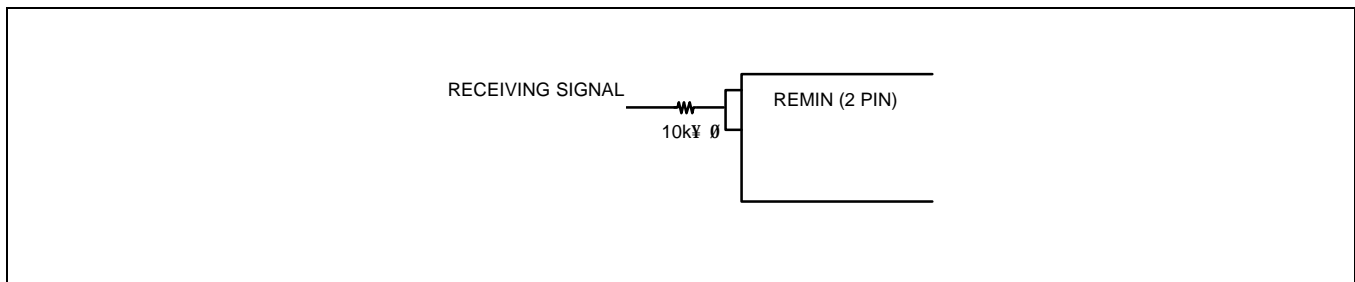

Figure 13.

APPLICATION CIRCUITS

1. RECEIVING PART

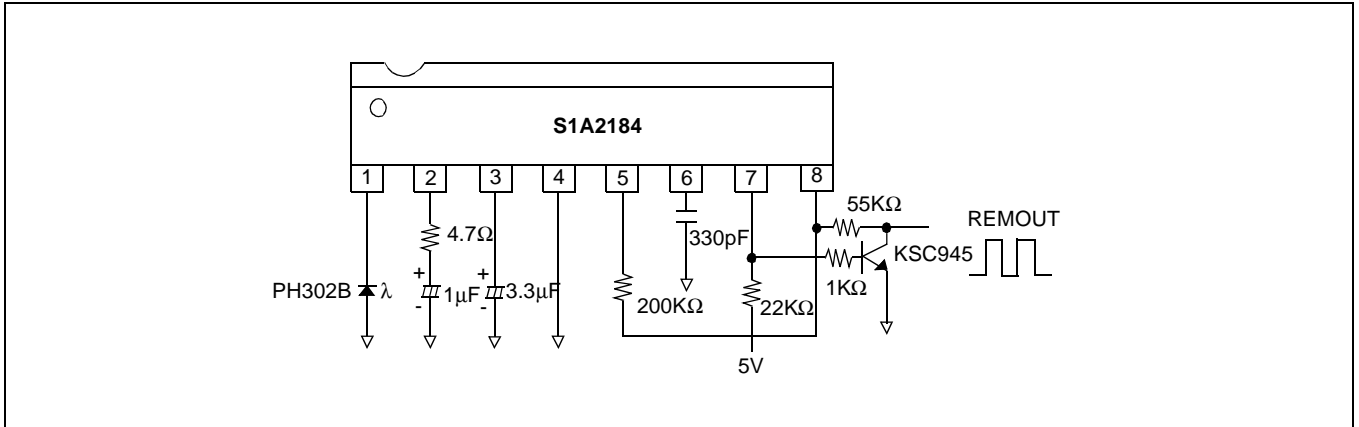

Figure 14.

2. S5G9801 CIRCUIT

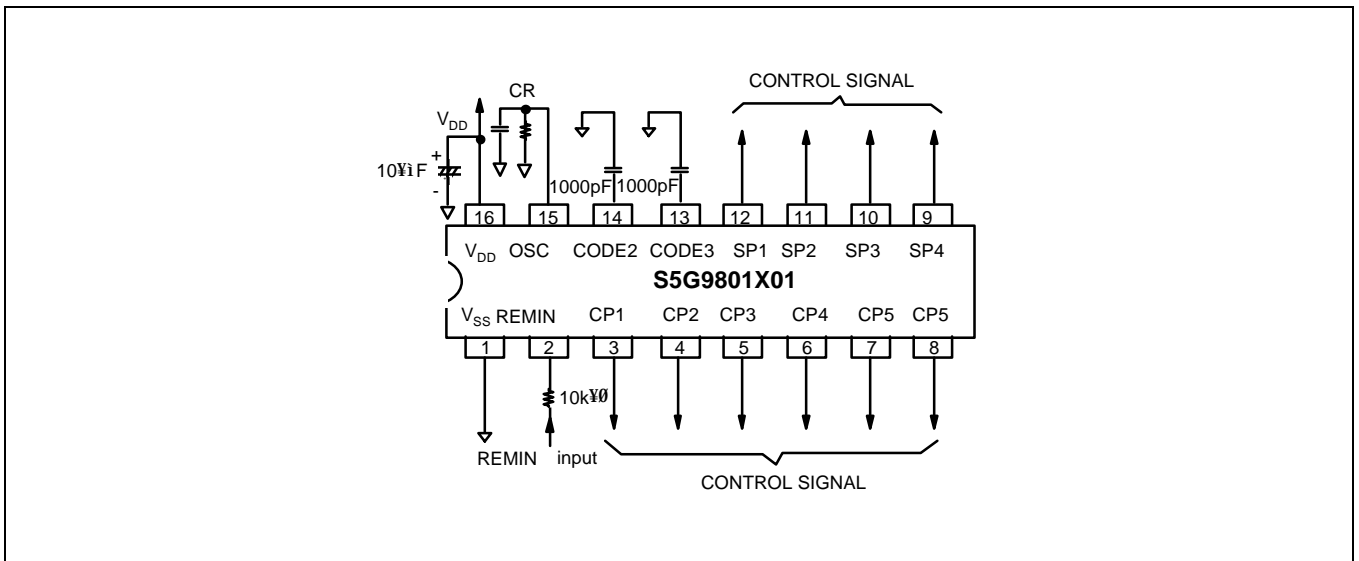

Figure 15.

3. S5G9803 CIRCUIT

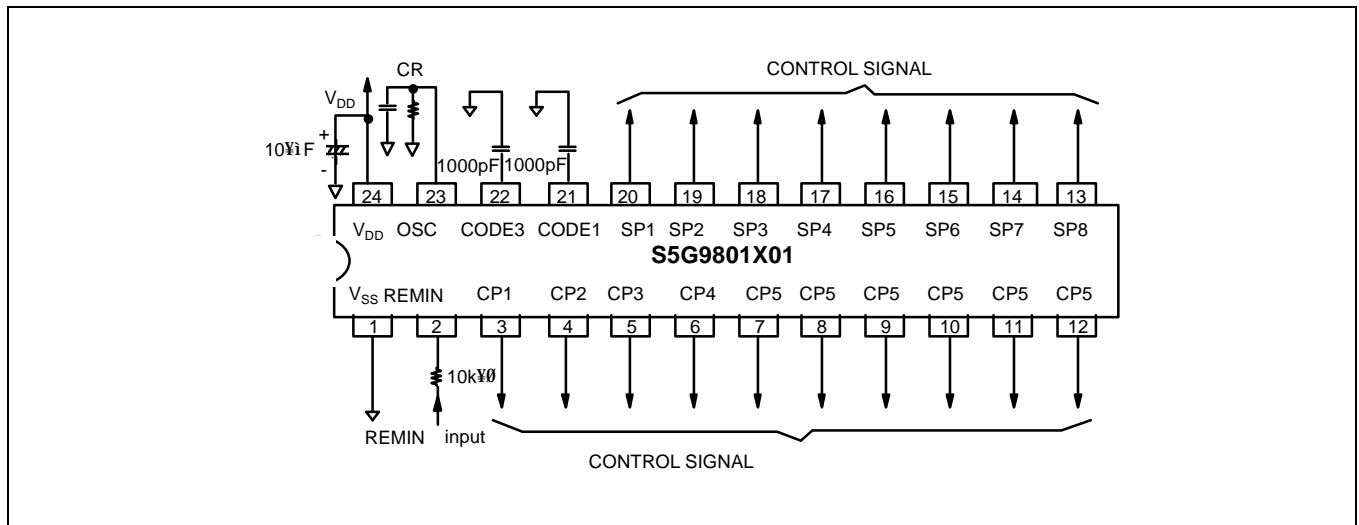
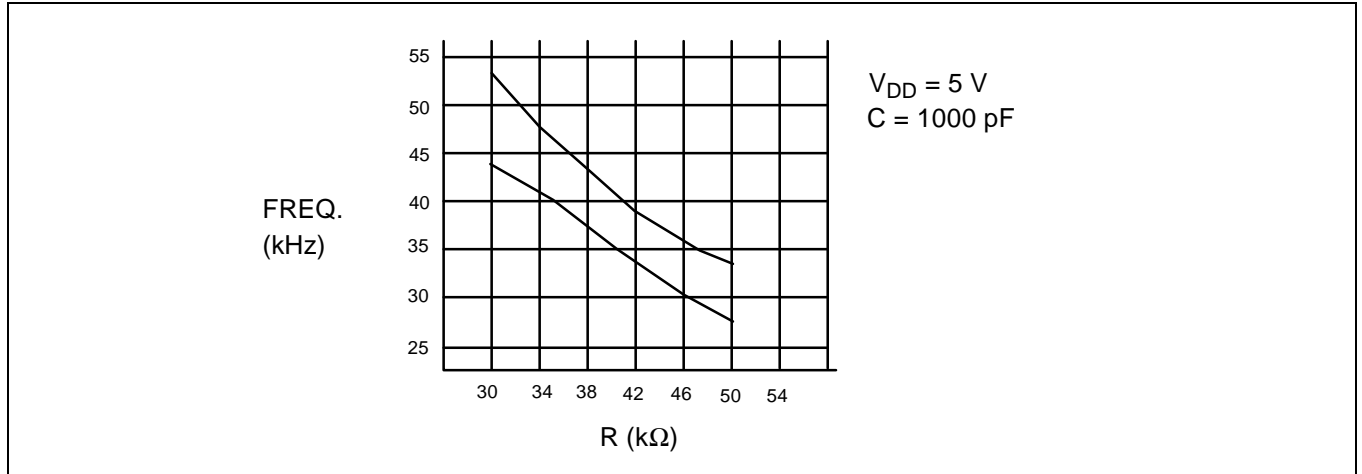

Figure 16.

VARIANCE OF OSCILLATION FREQUENCY BY R AND C

1) Variance of Oscillation Frequency by R



2) Variance of Oscillation Frequency by C

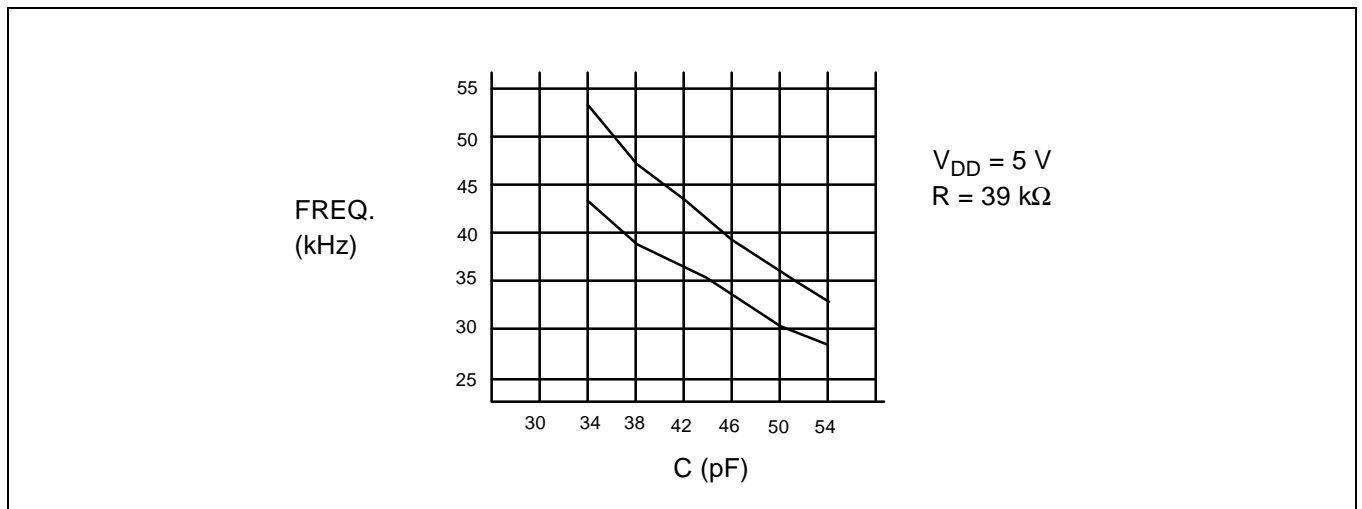

NOTES